

Lithium Batteries Best Practice - 016

Important Notes for All Lithium Cells / Batteries of All Sections:

- Each cell and battery must have completed the UN38.3 test.
- **Manufacturers and subsequent distributors of cells / batteries manufactured after 30 June 2003 must make available the test summary as specified in the UN38.3 test from 1 January 2020.**
- Section IA / I batteries manufactured after 31 December 2011 and Section IB / Section II batteries manufactured after 1 January 2009 must be marked with the watt-hour rating on the outside case.
- Cells and batteries must be manufactured under a quality management programme.
- Waste cells and batteries, cells and batteries identified by the manufacturer as being defective for safety reasons, or that have been damaged, having the potential of producing a dangerous evolution of heat, fire or short circuit are forbidden for air transport.
- Cells and batteries must be protected so as to prevent short circuits, and equipment must be equipped with an effective means of preventing accidental activation.
- Subject to the decision of individual carriers, relevant supporting documents of the shipment could be requested from shippers / forwarders. Supporting documents can be in the form of UN38.3 test report, UN38.3 test summary or SDS, or others, such as Product Data Sheet (PDS), and Product Information Sheet (PIS) that meet the acceptance needs of individual carriers.

Best Practice for Consigning Lithium Cells / Batteries in Hong Kong

Following the latest changes on the air transport of Lithium Cells / Batteries shipment as per the 60th edition of the IATA Dangerous Goods Regulations, the Lithium Battery Best Practice 016 will replace Best Practice 015 and take effect from 1 January 2019 until 31 December 2019. Shippers consigning Lithium Cells and / or Batteries from 1 January 2019 and onwards are recommended to follow the best practice as stated below.

The best practice is jointly issued by the Carrier Liaison Group – Dangerous Goods Working Group (CLG – DGWG) and HAFFA. It is a recommended practice (not mandatory) for industry reference only. **Shippers and freight forwarders shall always follow the IATA Dangerous Goods Regulations, requirement of the HK Civil Aviation Department and requirement of individual carriers for the air carriage of shipments containing lithium batteries at all times.**

States' and operators' variations shall always be observed.

This guideline consists of five parts,

Part 1 – Lithium Cells / Batteries (UN 3480 & UN 3090)

Part 2 – Lithium Cells / Batteries Packed with / Contained in Equipment (UN 3481 / UN 3091)

Part 3 – Lithium Battery Label & Mark

Part 4 – “Adequate Instruction” for Shipping Section II Lithium Batteries

Part 5 – Shipper's Letter of Instruction (SLI)

Part 1 – Lithium Cells / Batteries

A. Overview of Lithium Ion (UN 3480) & Lithium Metal (UN 3090) Cells / Batteries

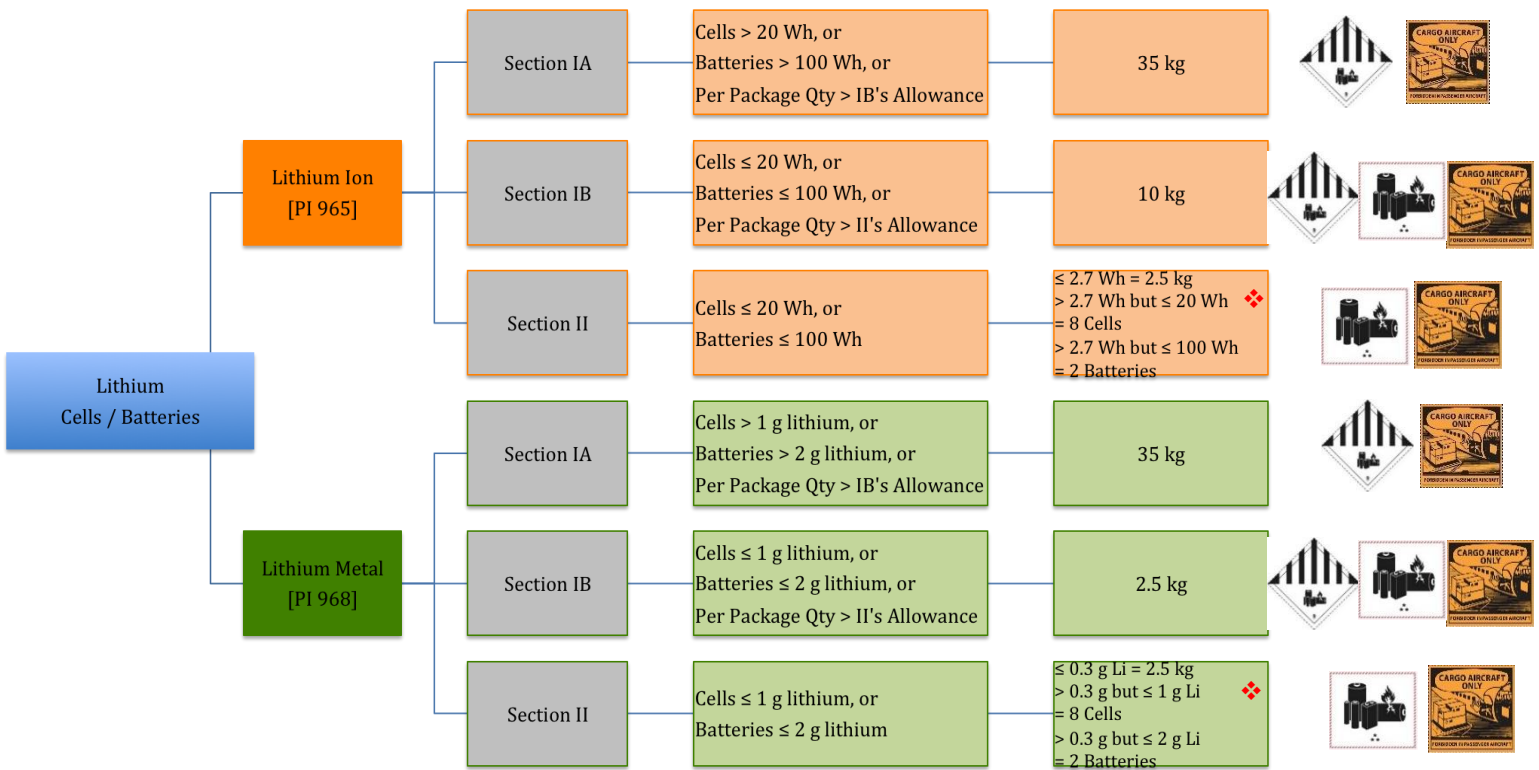

❖ Cells and batteries within the three ranges of watt-hour rating or lithium content listed must not be combined in the same package (i.e. shippers must not combine 4 cells with no more than 20 Wh together with 1 battery with no more than 100 Wh in a single package).

B. Documentation Requirements

Section IA

- Shipper's Declaration for Dangerous Goods (DGD) form.
- An Air Waybill (MAWB) with the following information indicated in the "Handling Information" box:
 - "Dangerous goods as per attached Shipper's Declaration" or "Dangerous Goods as per attached DGD",
 - "Cargo Aircraft Only" or "CAO".

Section IB

- Shipper's Declaration for Dangerous Goods (DGD) form.
- An Air Waybill (MAWB) with the following information indicated in the "Handling Information" box:
 - "Dangerous goods as per attached Shipper's Declaration" or "Dangerous Goods as per attached DGD",
 - "Cargo Aircraft Only" or "CAO".

Section II

- An Air Waybill (MAWB) with the following information indicated. The information should be shown in the "Nature & Quantity of Goods" box:
 - "Lithium ion batteries in compliance with Section II of PI 965" or "Lithium metal batteries in compliance with Section II of PI 968".
 - "Cargo Aircraft Only" or "CAO".

C. Packaging & Labelling Requirements

Section IA

- Must be placed in inner packagings before placing in a UN Specification outer packaging that meets the Packing Group II performance standard.
- Class 9 lithium battery hazard label and Cargo Aircraft Only label must be affixed on the package.

Section IB

- Must be placed in inner packagings before placing in a strong rigid outer packaging. Each package must be capable of withstanding a 1.2 m drop test in any orientation.
- Class 9 lithium battery hazard label, lithium battery mark and Cargo Aircraft Only label must be affixed on the package.

Section II

- Must be placed in inner packagings before placing in a strong rigid outer packaging. Each package must be capable of withstanding a 1.2 m drop test in any orientation.
- Lithium battery mark and Cargo Aircraft Only label must be affixed on the package.

D. Packing Requirements

Section IA

- Must not be packed in the same outer packaging with dangerous goods classified as Class 1 (explosives) other than Division 1.4S, Division 2.1 (flammable gases), Class 3 (flammable liquids), Division 4.1 (flammable solids) or Division 5.1 (oxidizers).

Section IB

- Must not be packed in the same outer packaging with dangerous goods classified in Class 1 (explosives) other than Division 1.4S, Division 2.1 (flammable gases), Class 3 (flammable liquids), Division 4.1 (flammable solids) or Division 5.1 (oxidizers).

Section II

- No more than one package in any single consignment. (*Consignment: one or more packages of dangerous goods accepted by an operator from one shipper at one time and at one address, receipted for in one lot and moving to one consignee at one destination address*)
- Packages must be tendered in loose to airlines (no pre-packed unit is permitted).
- No more than one package may be placed in an overpack. The overpack must not contain dangerous goods classified in Class 1 (explosives) other than Division 1.4S, Division 2.1 (flammable gases), Class 3 (flammable liquids), Division 4.1 (flammable solids) or Division 5.1 (oxidizers). The word “Overpack” must be at least 12 mm high.

E. Additional Requirements (Hybrid Lithium Battery and SP A213)

Contains both lithium metal cells and lithium ion cells that is not designed to be charged externally. They must meet the following conditions:

- The lithium ion cells can only be charged from the lithium metal cells;
- Overcharge of the lithium ion cells is precluded by design;
- The battery has been tested as a lithium metal battery;
- Component cells must have passed the respective UN 38.3 test;
- Must be assigned to UN 3090 or UN 3091, as appropriate.

IMPORTANT

- UN 3480 (lithium ion cells and batteries) must be offered for transport at a state of charge (SoC) not exceeding 30%. Cells / batteries might only be shipped at over 30% SoC with the approval of the State of Origin and State of Operator, and must be assigned to either Section IA or Section IB, whichever is relevant.

Part 2 – Lithium Cells / Batteries Packed with / Contained in Equipment (UN 3481 / UN 3091)

A. Overview of Cells / Batteries Packed with / Contained in Equipment (UN 3481 / UN 3091)

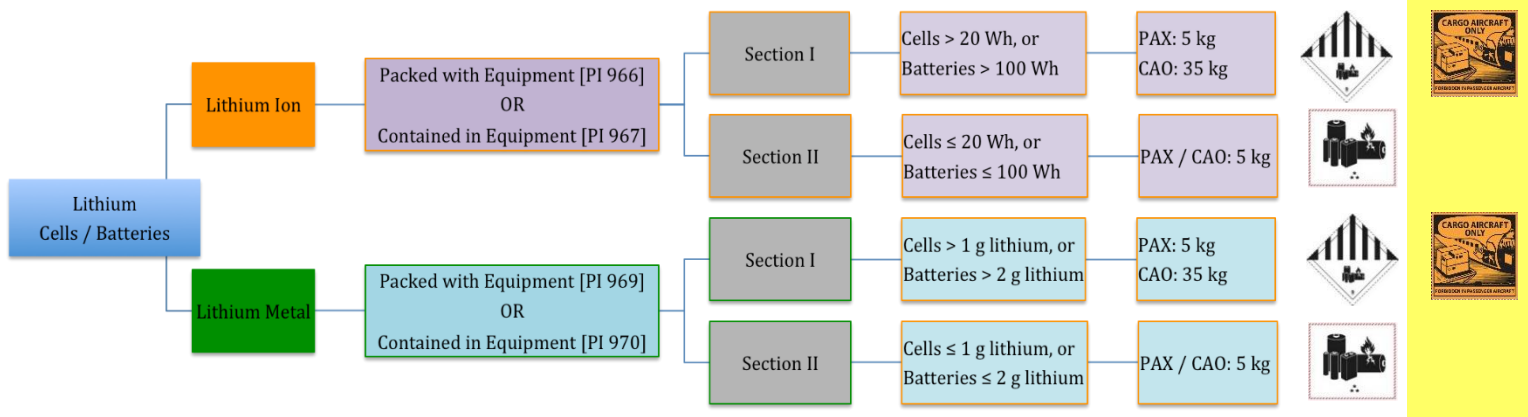

NOTE: “**Equipment**” means the device or apparatus for which the lithium cells or batteries will provide electric power for its operation.

B. Documentation Requirement

Section I

- Shipper’s Declaration for Dangerous Goods (DGD) form.
- An Air Waybill (MAWB) with the following information indicated in the “Handling Information” box:
 - “Dangerous goods as per attached Shipper’s Declaration” or “Dangerous Goods as per attached DGD”.

Section II

- An Air Waybill (MAWB) with the following information indicated. The information should be shown in the “Nature & Quantity of Goods” box:
 - “Lithium ion batteries in compliance with Section II of PI 966 (or PI 967, when applicable)” or “Lithium metal batteries in compliance with Section II of PI 969 (or PI 970, when applicable)”.

C. Packaging & Labelling Requirements

Section I

- PI 966, PI 969: Must be placed in inner packagings before placing in a UN Specification outer packaging that meets the Packing Group II performance standard.
- PI 969: When prepared for transport on Passenger Aircraft, must be packed in a rigid metal intermediate or metal outer packaging.
- PI 967, PI 970: Must be packed in strong rigid outer packagings.
- Class 9 lithium battery hazard label must be affixed on the package. Cargo Aircraft Only label must be affixed on the package if it is intended for transport on Cargo Aircraft Only.

Section II

- Must be placed in inner packagings before placing in a strong rigid outer packaging. Each package must be capable of withstanding a 1.2 m drop test in any orientation.
- Lithium battery mark must be affixed on the package.

D. Packing Requirements

[PI966 / PI969] The number of cells or batteries in each package must not exceed the number required for the equipment to operate, plus 2 spare sets.

E. Exceptional Handling [PI967 / PI970]

Lithium battery mark is NOT REQUIRED to be affixed, when:

- The packages contain only button cell batteries installed in equipment (including circuit boards); or
- The packages contain no more than 4 cells or no more than 2 batteries installed in equipment and no more than two of these packages per consignment under **Section II** of PI967 / PI970

What is a consignment?

“One or more packages of dangerous goods accepted by an operator from one shipper at one time and at one address, receipted for in one lot and moving to one consignee at one destination address.” (IATA Dangerous Goods Regulations Appendix A)

Below are some sample scenarios on how the number of consignments shall be counted:

Scenario	MAWB	HAWB	Number of Consignments
1	1 MAWB	Nil	1
2	1 MAWB	2 HAWBs HAWB 1 = Shipper A to Consignee A HAWB 2 = Shipper A to Consignee B	2
3	1 MAWB	2 HAWBs HAWB 1 = Shipper A to Consignee A HAWB 2 = Shipper B to Consignee A	2
4	1 MAWB	2 HAWBs HAWB 1 = Shipper A to Consignee A HAWB 2 = Shipper A to Consignee A	1
5	10 MAWBs MAWB 1 – 10 = Shipper A to Consignee A, pre-packed / loose, tendered at the same time	Nil	1

***NOTE:** Some regulators might have a different interpretation on the term “consignment”, shippers / freight forwarders are suggested to contact individual airlines to confirm the requirement.

F. Additional Requirements (SP A181 and PI 966 / PI 969)

When a package contains a combination of lithium batteries packed with equipment (PI 966 / PI 969) and lithium batteries contained in equipment (PI 967 / PI 970), the following requirements apply:

- All parts of both packing instructions are met.
- The total weight of lithium batteries contained in any package must not exceed the limits for passenger aircraft or cargo aircraft.
- Section I:
 - Mark UN 3481 Lithium ion batteries packed with equipment on the package, or UN 3091 Lithium metal batteries packed with equipment, as appropriate.
 - Declare UN 3481 Lithium ion batteries, or UN 3091 Lithium metal batteries packed with equipment on the Shipper’s Declaration for Dangerous Goods Form (DGD), as appropriate.
- Section II:
 - Declare “lithium ion batteries, in compliance with Section II of PI 966” or “lithium metal batteries, in compliance with Section II of PI 969” on the air waybill (MAWB), as appropriate.

Part 3 – Lithium Battery Hazard Label & Mark

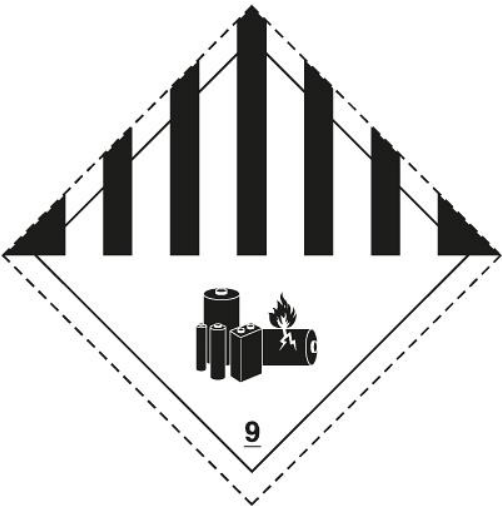
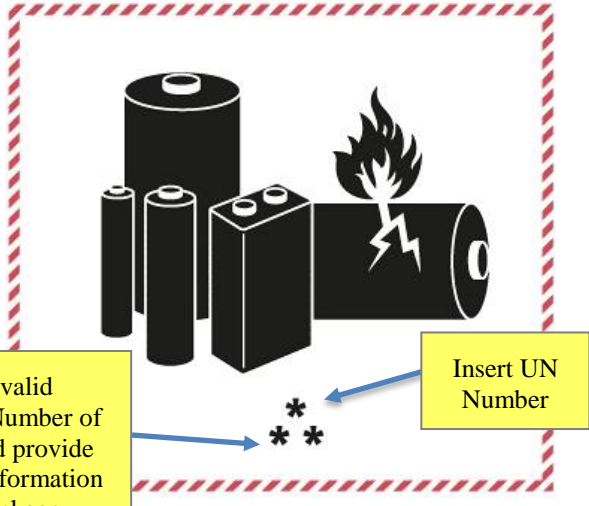
<p>Class 9 Lithium Battery Hazard Label for Section I, IA and IB</p>	<p>Lithium Battery Mark for Section IB and II</p>
	
<p>Size: 100 x 100 mm</p>	<p>Size: 120 mm wide x 110 mm high</p> <ul style="list-style-type: none"> • The label must have red diagonal hatchings (black and white photocopied labels are not permitted!!!) • The lithium battery mark must be completed with the UN number and a valid telephone number. • Smaller size label, 105 mm wide x 74 mm high, can only be used when the package is of dimension without sufficient space for the standard label!!! • The mark can be printed on the outer packaging but must have sufficient contrast and the specification is met

Part 4 – Adequate Instruction for Shipping Section II Lithium Batteries

It is mandatory for persons preparing or offering cells or batteries for transport to receive adequate instruction on the Section II lithium battery shipping requirements commensurate with their responsibilities.

IATA recommends employees shipping Section II lithium battery shipments be provided with knowledge on the following areas at a minimum of every two years, or as the documented instructions or regulations are revised.

- Classification of lithium batteries being shipped.
- Documentation of procedures applied to the lithium batteries being shipped.
- Written work instructions or other documentation.
- Reverse logistics, include transport mode and applicable prohibitions (if required).

The instruction given should be recorded with the date(s).

Part 5 – Shipper’s Letter of Instruction (SLI)

Shippers must clearly indicate below information on SLI:

- The type of cells or batteries: Lithium ion cells / Lithium ion batteries / Lithium metal cells / Lithium metal batteries.
- The relevant Packing Instruction: “PI965 / PI966 / PI967 / PI968 / PI969 / PI970”.
- Section of Packing Instruction referring: “Section I / Section IA / Section IB / Section II”.

– END –